

Causes of Cracks on Concrete Structures and Repair Methods

Grace Agbons Aruya

Department of Civil Engineering Technology, Auchi Polytechnic, Auchi, Edo State, Nigeria

Victor Kosidimma Chukwuemezie

Department of Civil Engineering, University of Nigeria Nsukka, Enugu State, Nigeria

Abstract: Cracks are a regular occurrence in structures, and they commonly manifest flaws over time or as a result of the building's construction. There are various reasons for cracks in concrete structures. They may reveal the full amount of the injury or more serious issues. They could indicate serious structural deterioration, a lack of durability, or simply affect aesthetics. Different sorts of cracks arise on structures due to mistakes made during construction and certain unavoidable factors; they are categorized as structural and non-structural cracks. Structural cracks are caused by wrong design, defective construction, poor quality and material, and overloading, all of which can jeopardize a structure's safety. Corrosion of reinforcement, thermal movement, creep movement, chemical reaction, and other factors can cause nonstructural fractures. Cracks in concrete can't be completely avoided, but they can be controlled with the right materials and repair techniques. The goal of this research is to characterize cracks to prescribe optimal maintenance and repair procedures.

Keywords: Cracks, Buildings, Prevention, Causes, Repair.

1. Introduction

Diverse crack patterns in the building frequently appear during construction, after completion when subjected to additional load, or when the building is in use [1]. When the stress in a building component exceeds its strength, cracks form. Modern buildings are designed for larger loads, have thin walls, are generally tall and slender, and are built quickly. Because of this, they are more prone to cracking than older buildings that were low, had strong walls, were barely stressed, and were constructed more slowly. Furthermore, modern structures with thin walls are easily susceptible to moisture from rain entering and deteriorating the coating. Due to current development trends, measures to control building cracks have thus become much more important [2]. Internal heat movements, moisture changes, chemical reactions, etc. could all cause it.

Most structures develop cracks at some point throughout their useful lives. A building's fabric is in distress when a crack appears, which is a symptom. Internal stresses accumulate to a point where they surpass the material's rupture strength, which leads to cracking in brittle materials like brickwork. The fracture forms once the rupture strength is exceeded, and internal tensions are released. These stresses are typically brought on by the building's movements due to unequal foundation settlements, temperature fluctuations, shrinkage brought on by changes in moisture content, chemical processes, or creep deformations of materials. There are numerous fissures in concrete construction. Before the maximum load is reached, extensive cracking zones and huge fractures frequently emerge in concrete structures, which leads to their failure [3]. Cracks can be mainly split into two groups:

- I. **Structural Cracks:** Cracks in the structure that result from poor design, shoddy construction, or overloading pose a threat to a building's structural integrity [4]. An RCC beam with extensive cracking is an example of structural cracking. There are three types of structural cracks: cracks in slabs (flexural, shrinkage, and corrosion cracks), cracks in columns (horizontal, diagonal, corrosion cracks), and cracks in beams (flexural, shear, torsional, corrosion cracks).
- II. **Non-structural Cracks:** Internally induced tensions in construction materials are the main cause of non-structural cracks, which often do not immediately degrade the structure [5]. But occasionally, non-structural flaws might cause the reinforcement to corrode over time due to moisture seeping in via the gaps or weathering action, making the structure dangerous. Nonstructural cracking occurs when horizontal fractures appear in a long compound wall as a result of shrinkage or heat fluctuation.

2. Key Factors that Contribute to Cracks in Buildings and Remedy

a. Permeability of concrete

Concrete permeability is influenced by several variables, including the age of the concrete, the water-to-cement ratio, admixture use, curing, air spaces from inadequate compaction, microcracks from loading, and the usage of admixtures. It determines how resistant concrete is to deterioration processes including chemical deterioration and weathering. The first three also relate to the durability of concrete. Given high-quality components, appropriate proportions, and sound construction practices, the water-cement ratio determines the cement paste's permeability [6]. Conversely, the cement paste's porosity and interconnectivity determine the concrete's permeability.

Remedial Action

It is recommended that appropriate steps be made to reduce concrete permeability and, consequently, cracks.

b. Thermal movement

Temperature changes, component size, coefficient of thermal expansion, and other material physical characteristics are only a few of the variables that affect how a component moves thermally. Temperature differences and subsequent thermal movement are caused by changes in ambient temperature and the heat of hydration being lost from various parts of a structure at varying rates.

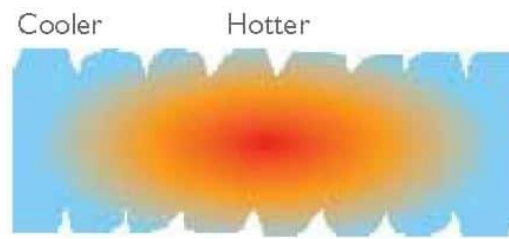

Figure 1: Thermal Movement

In general, temperature variation in internal walls and intermediate floors is minimal and does not result in cracking. The external walls that are directly exposed to sunlight and the roof, both of which experience significant heat variation, are the two main structural components that are more prone to cracking [7].

Remedial Action

- When designing and building appropriately, joints should be taken into account. Examples include slide joints, control joints, expansion joints, and construction joints.

c. Creep movement

Creep is the name given to the slow, gradual distortion that occurs over time as a concrete structure is subjected to sustained loads. There could be an excessive amount of stress created, which would cause a crack to form. Creep rises as temperature, the percentage of water to cement, and its contents rise[8]. The creep will also be exacerbated by admixtures and pozzolans. Additionally, creep will increase as steel bar temperatures rise.

But as the surrounding air becomes more humid and the material gets older at the moment of loading, it gets less.

Remedial measures: Large coarse aggregate should be used, along with the least amount of water possible. Additionally, compression reinforcement ought to be offered if at all possible, and formwork removal at a young age ought to be avoided. Concrete ought to be given adequate time to cure. The concrete piece should be given a suitable cross-section.

d. Corrosion of reinforcement

If reinforcement isn't properly protected, rusting will happen. Steel reinforcement can be safeguarded by covering it with enough impermeable concrete. This will stop moisture and other harmful materials from entering. Iron oxide and hydroxide will be produced by reinforcement corrosion on the surface of the steel bar, increasing its volume[9][10].

This elevation of volume results in localized radial cracks and strong radial bursting strains around reinforcing bars. These splitting cracks cause longitudinal cracks to grow parallel to the bar. As long as the concrete that surrounds it has a high pH value and is alkaline, steel corrosion won't happen either.

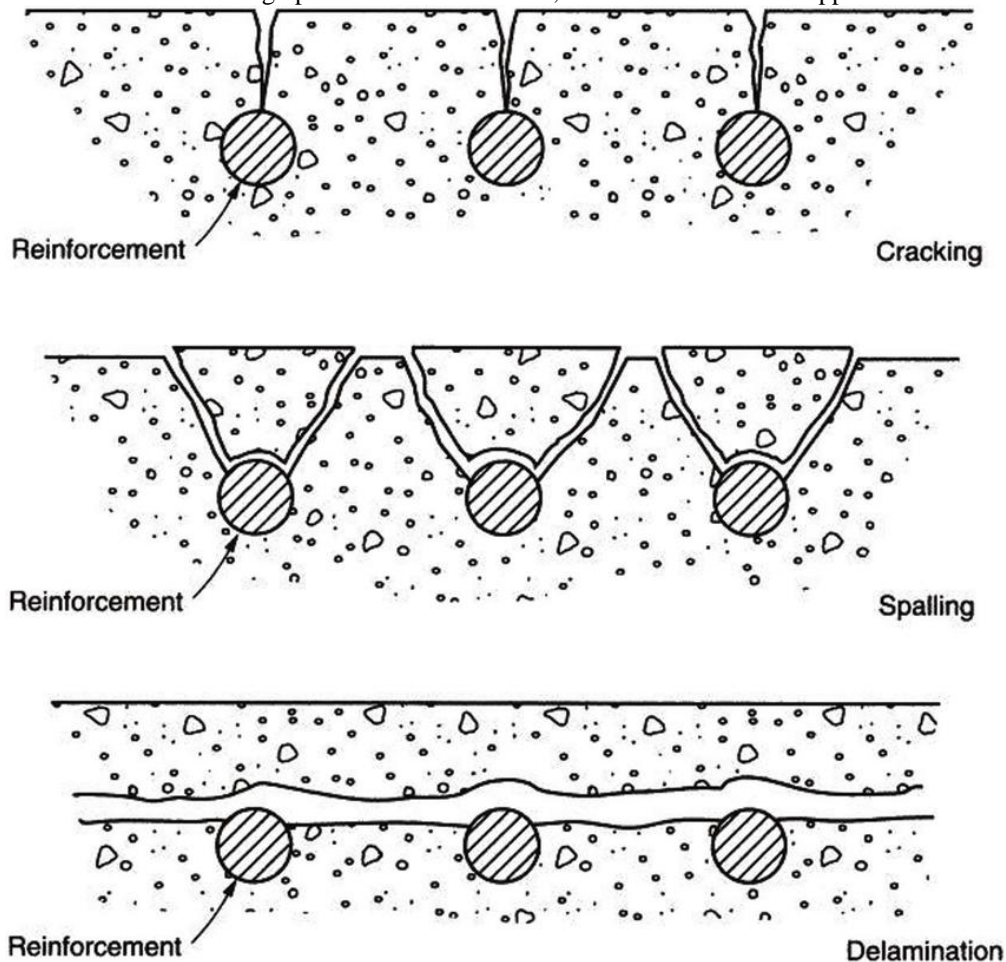

Figure 2: Corrosion of the reinforcement[11].

Remedial Action

- Use concrete that has low permeability.
- Put enough thickness on the cover.
- Ensure the steel-concrete bond is as strong as possible. This is because concrete cannot, by itself, withstand the tensile stresses to which it is frequently exposed. In the absence of this, concrete may break, allowing dangerous chemicals to assault steel bars.

e. Moisture movement

The majority of construction materials have intermolecular spaces that act as pores, which cause them to expand when wet and contract when dry.

These cyclical movements are brought on by variations in moisture levels, which also raise or reduce inter-pore pressure. Dry or plastic can shrink. Excessive water and cement quantity are two factors that cause cement or mortar to shrink; richer cement compositions experience greater shrinking.

Remedial measures

- Give joints for mobility
- When mixing cement, concrete, or mortar, use the least amount of water feasible.
- Concrete must be adequately compacted; vibrated concrete experiences less shrinkage than manually compacted concrete. And finally, it's best to refrain from using too much cement.

f. Movement due to chemical reactions

The expanding interactions between the alkaline produced by cement hydration and the aggregate, which contains active silica, could cause the concrete to break. A gel that is prone to swelling develops as a result of the alkali-silica reaction [12]. This tends to pull water from other concrete areas. As a result, there is local expansion, which causes cracks in the structure.

Remedial Actions

- Employ low-alkali cement.
- Use pozzolana.
- Choose appropriate aggregates.

g. Poor construction practices

Concrete can crack due to a wide range of construction methods. Ignorance, carelessness, or avarice are typically the causes of faulty construction techniques [13].

Inadequate construction methods' primary causes are:

1. Improper material selection.
2. Selection of inexpensive, low-quality materials.
3. Inadequate and incorrect mixing of mortar, concrete, and other mixed components.
4. Control issues at many stages of the manufacturing of concrete, including batching, mixing, transportation, putting, finishing, and curing.
5. Overloads brought about by construction are typically more severe than those brought about by service.
6. Large voids (honeycombs) and cracks brought on by poor quality control and supervision ultimately accelerate the deterioration of concrete.
7. Improperly built joints between successive pours of concrete or between a concrete structure and masonry.
8. Excessive water addition to concrete and mortar mixtures.
9. Last but not least, subpar plumbing and sanitary techniques and materials.

Remedial Action

- Adequate track of the construction process should be done and building materials of high quality be used.

h. Improper structural design and specifications

At this phase, mistakes can include inadequate thickness, insufficient reinforcement, inaccurate geometry, inefficient material use, and inappropriate detailing. These mistakes can lead to issues including inadequate reinforcement causing cracking, inappropriate foundation design causing excessive differential movement, and improperly planned re-entrants causing higher stress concentration [14].

The designer must also take into account the environmental factors in the area surrounding the construction site.

Remedial measures

- Concrete and its components should be properly specified.
- The right specs address the sub-soil and environmental conditions.
- Structural design that is feasible and suitable.
- The concrete that surrounds the reinforcement steel is of proper grade and thickness.
- To enable proper concrete placement without segregation, consider a proper reinforcing architecture and detail it in thin constructions.

i. Poor maintenance

After a predetermined amount of time has passed after the end of construction, a structure needs to be maintained. Depending on the caliber of design and construction, some structures may require an early examination of their deterioration issues, while others might maintain themselves admirably for many years. Additionally, frequent exterior painting of the building can aid in a limited way of protecting it from chemical and moisture damage [15].

Second lines of defense, such as waterproofing and shielding materials for reinforced concrete or steel, all rely heavily on the quality of the concrete for their protection to be effective. Before the steel corrodes inside the concrete and the concrete begins to spill, leaks should be fixed as soon as possible. Spalled concrete will also

lose its stiffness and strength. Additionally, as a result of the rusty steel being completely exposed to a hostile environment, the rate of corrosion accelerates.

Last but not least, it is crucial to avoid dampness and harsh chemicals from penetrating concrete and causing further damage. This is just as important as fixing the concrete that has already deteriorated.

Other elements, such as a little earthquake or a fire.

2.1 General causes of cracks

Some of the general causes of cracks are listed below;

- I. Bricks of poor quality.
- II. Using porous stones for masonry projects.
- III. No grading before using fine aggregate or fine mortar.
- IV. If the fine aggregate contains more than 3% clay and silt.
- V. Excess soluble sulfate.
- VI. Slender alignment.
- VII. Differing loads.
- VIII. Flimsy mortar.
- IX. Incorrect curing.
- X. Considerable daily temperature changes.
- XI. Contaminants in the atmosphere.
- XII. Incorrectly binding thick walls.

2.2 Causes of cracks in concrete structure

a) Plastic shrinkage cracking: When exposed to a very quick loss of moisture brought on by several conditions, such as air and concrete temperatures, relative humidity, and wind speed at the concrete's surface, it happens within one to eight hours of the concrete being placed. In both hot and cold climates, these elements may interact to produce significant rates of surface evaporation [16].



Figure 3: Plastic shrinkage crack.

b) Plastic settlement cracking: Concrete tends to continue to consolidate after it has been initially placed, vibrated, and finished. By using formwork, previously set hardened concrete, or reinforcing steel, the plastic

concrete may be locally constrained during this time. the neighborhood floor. Figure 4 shows how the settlement has caused a crack and void.

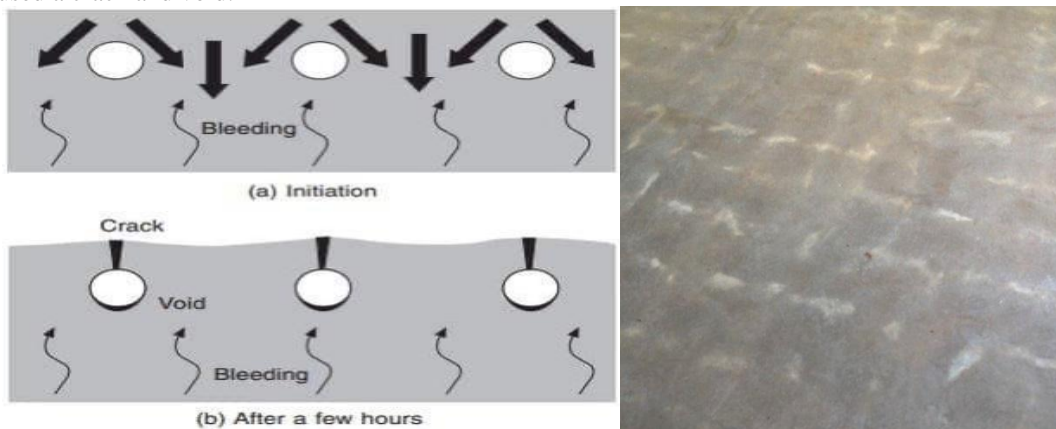

Figure 4: Plastic settlement cracking [17].

c) Drying shrinkage crack: Settlement cracking, which is related to reinforcing steel, rises with larger bar sizes, more slump, and less cover. With insufficient vibration, insufficient compaction of the top layers of concrete, or the use of leaking or extremely flexible forms, the degree of settlement may increase. This is more of an issue with high bleed concrete, especially in the winter when the cooler temperatures allow for a longer initial setting period and a greater quantity of bleed.



Figure 5: Drying Shrinkage crack [17].

d) Concrete crazing: When the top layer of concrete shrinks, a network of small, random cracks or fissures forms on the surface. Rarely deeper than mm, these fissures are more obvious on surfaces with steel trowels or floated over floated surfaces. Most of the time, the irregular hexagonal patches encircled by the fractures are no wider than 40 mm, though, in exceptional circumstances, they could be as small as 10 mm.



Figure 6: Concrete crazing [17].

e) Steel corrosion-induced cracking: Iron oxides and hydroxides, which have substantially larger volumes than the original metallic iron, are created during the corrosion of steel. High radial bursting stresses are produced by this volumetric increase, which leads to localized radial cracks.



Figure 7: Steel corrosion-induced cracking

3. Cracks Repair Methods

The act of repairing anything involves bringing it back to a functional or usable state that allows it to be used or operated after it has been damaged, broken, or failed. The crack-repair procedures include the following:

a) Epoxy injection

With this technique for fixing concrete cracks, epoxy is injected underneath the fracture to seal the gaps on exposed concrete surfaces. However, before injecting epoxy into the cracks, the primary cause of the cracks must be identified and fixed to prevent further cracking. It is advised to solve these difficulties before injecting the epoxy to prolong its effectiveness because leaks and silt contamination reduces the effectiveness of the material.



Figure 8: Epoxy Injection Method.

b) Crack stitching

A crack is stitched by drilling holes on both sides of it, then grouting the holes with the aid of U-shaped metal components that cover the crack. Tensile strength is lost relatively when fractures emerge, hence to regain this lost tensile strength stitching is utilized in conjunction with drilling holes, cleaning the holes, and filling the holes with grout that has a strong bond.

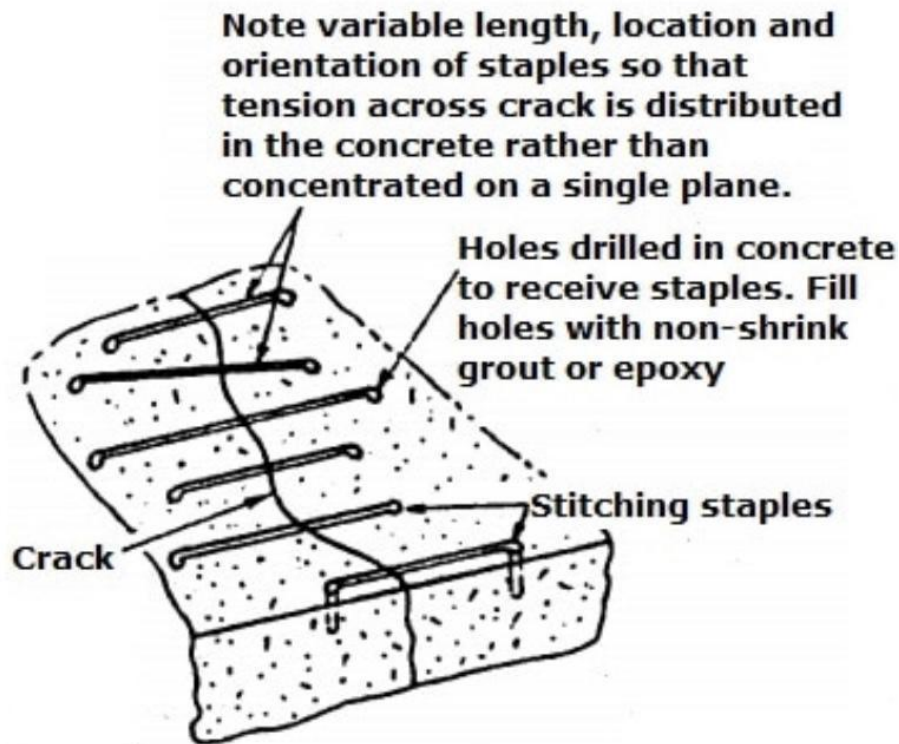

Figure 9: Using stitches to mend cracks

c) Routing and Sealing of cracks

When repairs and maintenance are necessary but building repairs are not required, this strategy is preferred. This procedure enlarges the fracture along the exposed face, which is then filled with an appropriate sealant [18]. In comparison to other treatments like epoxy injection, this is the most popular and affordable technique. Although routing and sealing can be done on curved, vertical, and horizontal surfaces, they are most commonly used on flat horizontal surfaces like slabs and pavements.

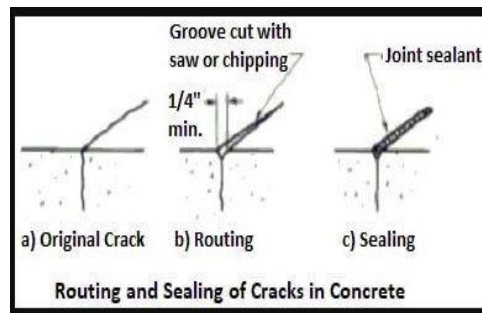

Figure 10: Routing and sealing of cracks.

d) Cementitious Grouts

Cracks with a wider opening are repaired with it. It consists of a proportional mixture of cementitious material and water that can be poured. Since cement-based grouts come in a wide range of consistencies, there are numerous application techniques available. The most cost-effective options for repair are these materials. They are reasonably safe to handle and do not require remarkable skill or specific equipment to apply. Due to subsequent hydration of cementitious materials at fracture surfaces, these materials—which frequently share characteristics with the parent concrete and mortar—can undergo autogenous healing. In this kind of grout, shrinkage is a worry. These are not appropriate for fixing active cracks in structures. In general, surface preparation, such as the elimination of loose debris, is required before applying cementitious grouts. A Saturated-Surface-Dry (SSD) condition should be attained through pre-wetting. Using a drill and paddle mixer, grouts should typically be mixed to a pourable consistency [4]. The consistency can then be changed as

needed. Filling all pores and voids requires application into vertical and above cracks using a hand trowel or dry packing. The next step is to coat the repaired surfaces with a suitable material.

e) Polymer impregnation

Methyl methacrylate is the most widely utilized monomer in this process. To effectively fix some fissures, this technology is heavily utilized. A liquid monomer system that will eventually polymerize into a solid is the monomer system used in this [19].

f) Drilling and plugging

Drilling is used in this procedure to fill or grout the crack in the form of a key once it has run its whole length. This method works best when the cracks are oriented as straight lines and are accessible from one end. Retaining wall cracks that run vertically are frequently repaired using this technique. In this operation, you should typically drill a hole that is 5075mm in diameter [20].

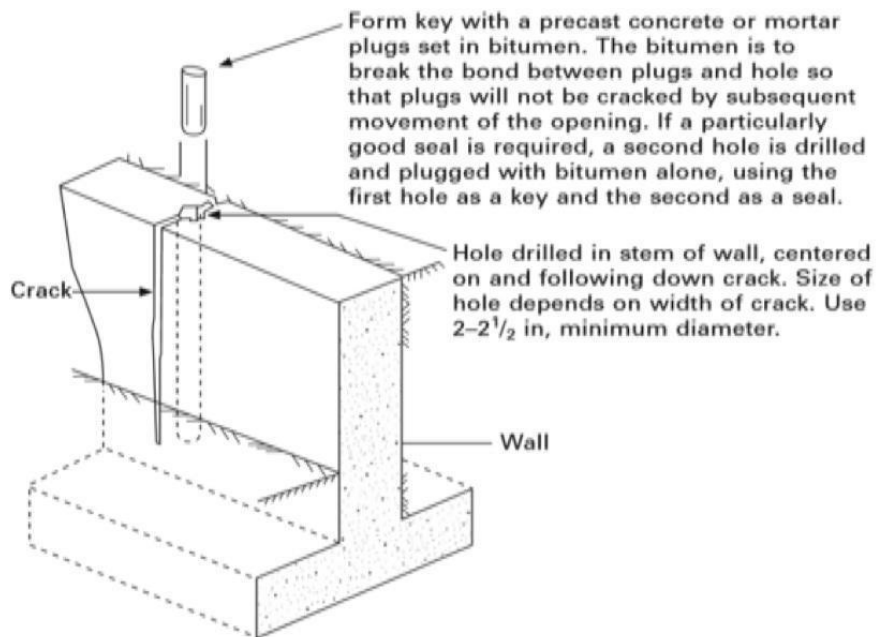

Figure 11: Drilling and Plugging method.

g) Sealing cracks with gravity filling:

When using gravity filling to seal fissures, resins and monomers with a relatively low viscosity are frequently used. High molecular weight urethanes and a few epoxies with low viscosity have both been utilized in the past with effectiveness. Typically, this procedure entails using water or air blasting to clean the surface. By employing this technique, it is understood that the smaller the filling's particle size, the easier it will be to fill fractures [21].

h) Dry packing:

It is the procedure for laying mortar with a low moisture content, which is then followed by tamping the mortar into a specific region. This method also aids in creating a tight bond and contact between the concrete and the mortar.



Figure 12: Dry Packing

4. Conclusion

As mentioned above, cracks can happen for a variety of causes. Several steps may be done to avoid the effects of cracks, but they cannot be prevented or eradicated. The construction process itself should address several preventative elements. A building's long-term degradation, which finally results in the demise of the structure, can be caused by careless observations and a lack of attention. It was concluded from this research that while cracking cannot be prevented, steps can be done to lessen its occurrence and progression inside the structure. By examining various cracks and their propensity to crack, it was also concluded that not all sorts of fractures require the same level of attention. If appropriate thought is given to the building method and material to be utilized, the potential causes of crack can be managed. We may reduce the issue of cracking in our structure if we pay attention to the primary causes of cracks in our buildings and act to prevent them at the outset.

References

- [1]. E. A. Jiya, N. S. N. Anwar, M. Z. Abdullah, "Detection of Cracks in Concrete Structure Using Microwave Imaging Technique", International Journal of Microwave Science and Technology, vol. 2016, Article ID 3195716, 6 pages, 2016. [\[CrossRef\]](#).
- [2]. Shivani More, Tejas Hirlekar, "A Review On Causes, Prevention, Repair And Maintenance Of Cracks In Building (Residential And Commercial)" International Research Journal of Engineering and Technology (IRJET) Volume: 04 Issue: 11 | Nov -2017, Page 1339.
- [3]. Ajagbe W.O., Ojedele O. S., "Structural Investigation into the Causes of Cracks in Building and Solutions: A Case Study "American Journal of Engineering Research (AJER) 2018 , Volume-7, Issue-8, pp-152-160.
- [4]. Chetan J. Chitte, Yogesh N. Sonawane "Study on Causes and Prevention of Cracks in Building" International Journal for Research in Applied Science & Engineering Technology (IJRASET) Volume 6 Issue III, March 2018, pp. 453 – 461.
- [5]. Dr. K. Chandrasekhar Reddy, P. Ashok, "Study on Generation, Causes, and Prevention of Cracks in Structural and Non-Structural Members in Buildings", Intl. Journal for Research in Engineering Application & Management, ISSN: 2454-9150, Vol-04, Issue-02, May 2018. Pp. 302-308.
- [6]. Prasad S. Barve, Dr. Lalit S. Thakur, Ruchi P. Barve, Jaimin K. Shah, Neha P. Patel," DETECTION AND SIZING STUDY OF CRACKS: A CASE STUDY", International Journal of Advance Research in Engineering, Science & Technology(IJAREST), Volume 2, Issue 8, pp.84-91, August- 2015.
- [7]. Xinzhuang Cui, Jiang Zhang, Dan Huang, et al, "Experimental Study on the Relationship between Permeability and Strength of Pervious Concrete", Journal of Materials in Civil Engineering, 29 (11) November 2017, [\[CrossRef\]](#).
- [8]. Aman Tiwari, Shubham Sawarkar, Shubham Kushwah, Rishabh Naroliya, "A Case Study of Cracks in Building: Causes and Repair (2018)" Intl. Journal of Research in Engineering, Science and Management Volume-1, Issue-4, April 2018.
- [9]. Rishabh Pathak, Deepak Rastogi (2017), "Case Study on Cracks in Public Buildings and their Remedies", International Journal of Science and Research (IJSR), Vol. 6 Issue 5, pp 325-329, [\[CrossRef\]](#).
- [10]. Kazem Reza Kashyzadeh, Neda Aghili Kesheh, "Study type of Cracks in construction and its controlling" International Journal of Emerging Technology and Advanced Engineering, Volume 2, Issue 8, August 2012.
- [11]. Maurya, K. K., Rawat, A., Shanker, R. (2022). Review Article on Condition Assessment of Structures Using Electro-Mechanical Impedance Technique. Structural Durability & Health Monitoring, 16(2), 97–128. [\[CrossRef\]](#).
- [12]. Rajveer Singh Narwaria, Archana Tiwari, "Development of cracks in concrete, preventive measures and treatment methods: A review" International Research Journal of Engineering and Technology (IRJET) Volume: 03 Issue: 09 | Sep -2016, Page 671.
- [13]. Grishma Thagunna," Building cracks – causes and remedies", International Journal of Advanced Structures and Geotechnical Engineering ISSN 2319- 5347, Vol. 04, No. 01, pp.16-20, January 2015, [\[CrossRef\]](#).
- [14]. AkandeBasirat F., Debo-Saiye B., Akinjobi Samuel D., Alao Timothy O. & Akinrogunde Oluwatoyin, "Causes, Effects and Remedies to the incessant Building Collapse in Lagos State, Nigeria" International Journal of Basic & Applied Sciences IJBAS-IJENS Vol: 16 No: 04, August 2016.
- [15]. Damudhar L. Sonani, Prof P. M. Attarde (2019), "Causes, Prevention And Repairing of Cracks In High Rise Building", Intl. Journal of Science And Research Vol. 5, Issue 11, Pp 39-45.

- [16]. Adje Kpie Janvier De Thales and Prof. KabirSadeghi. “Causes and Effects of Structural Cracks”, International Journal for Modern Trends in Science and Technology 2022, 8 pp. 64-69. [\[CrossRef\]](#).
- [17]. B.Ashoka Chakravarthi, Balaji Kvgd (2014), “A study of different types of cracks in plain and reinforced Concrete”. [\[CrossRef\]](#).
- [18]. Anitya S. Zanke (2020), “Building Cracks: Causes And Preventions”, International Journal of Engineering Applied Sciences and Technology, Vol. 5, Issue 8, ISSN No. 2455-2143, Pages 165-169, [\[Crossref\]](#).
- [19]. Kunal Kishor and Namesh Killemssetty. (2014). “Study on control of cracks in a Structure through Visual Identification & Inspection.” IOSR Journal of Mechanical and Civil Engineering. Vol. 11, No.5. pp. 64-72.
- [20]. Agu Ransford Tetteh, Ye Liang, "Repair of Cracks on Concrete Structures", International Journal of Science and Research (IJSR), Volume 9 Issue 4, April 2020, pp. 82-92, Volume 6 Issue 5, May 2017, [\[CrossRef\]](#).
- [21]. Pooja Nama, Ankush Jain, Rajat Srivastava and Yash Bhatia, “Study on Causes of Cracks & its Preventive Measures in Concrete Structures”, Intl. Journal of Engineering Research and Applications, Vol. 5, Issue 5, (Part -2) May 2015, pp.119-123.